

model 712/717  
slab saw

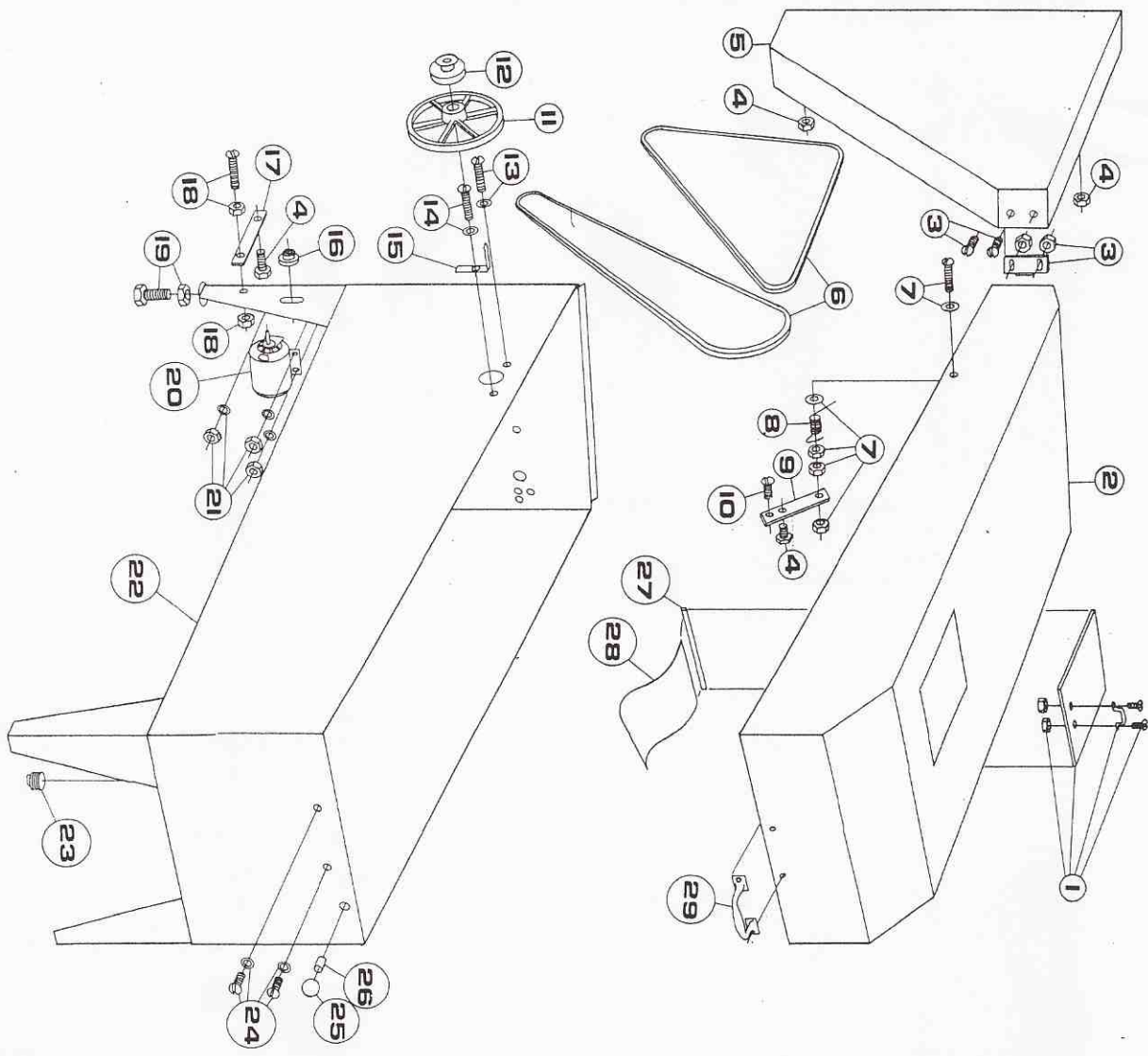

QTY	P/N	Description
1	1	plexiglass window & handle (479)
1	2	w/2 - #8-32 X 5/8 FHMS, washer & nut
1	3	hood
1	4	cabinet magnet assy (SP 46)
1	5	1/4"-20 X 1/2 HHMS
1	6	belt guard
2	7	V-belts (4L570 & 4L580)
1	8	5/16"-18 X 1-3/4 RHMS, 2-fender washer, 4-std & 1-lock nut
1	9	hood prop spring (C & M spr)
1	10	prop arm (Hutchison Mfg)
1	11	1/4"-20 X 1/2 THMS & locknut
1	12	8A X 1 pulley
1	13	SCZ4 X 5/8 (2-3 X 5/8 step) pulley
1	14	5/16"-18 X 1 THMS, lock washer & nut
1	15	5/16"-18 X 1-3/4 THMS, lock washer, 2-std nuts, fiber washer & locknut
1	16	blade guard bracket
1	17	2 1/2A X 5/8 motor pulley
1	18	lower belt guard bracket
1	19	#10-24 X 1 RHMS & 2-nuts
1	20	1/4"-13 X 1-3/4 HHMS leveling scr & nut
3	21	motor (5K453, 5K459, or 6K321)
1	22	5/16-18X HHMS, washers & nuts
1	23	body (tank)
1	24	1 1/2" drain plug (pipe)
1	25	1/4"-20 X 1 THMS & fiber washer
1	26	switch rod knob (Daves #30)
1	27	switch bushing (Lamcor SB-437-4)
1	28	curtain clip (aluminum)
1	29	splash curtain (polyethylene)
1	29	hood handle (#3, SP 482)

# Also part of #660, #661, or #662 Saw Kits  
\* Also part of #664, #665, or #666 Power Feed Kits

model 700 series

slab saw

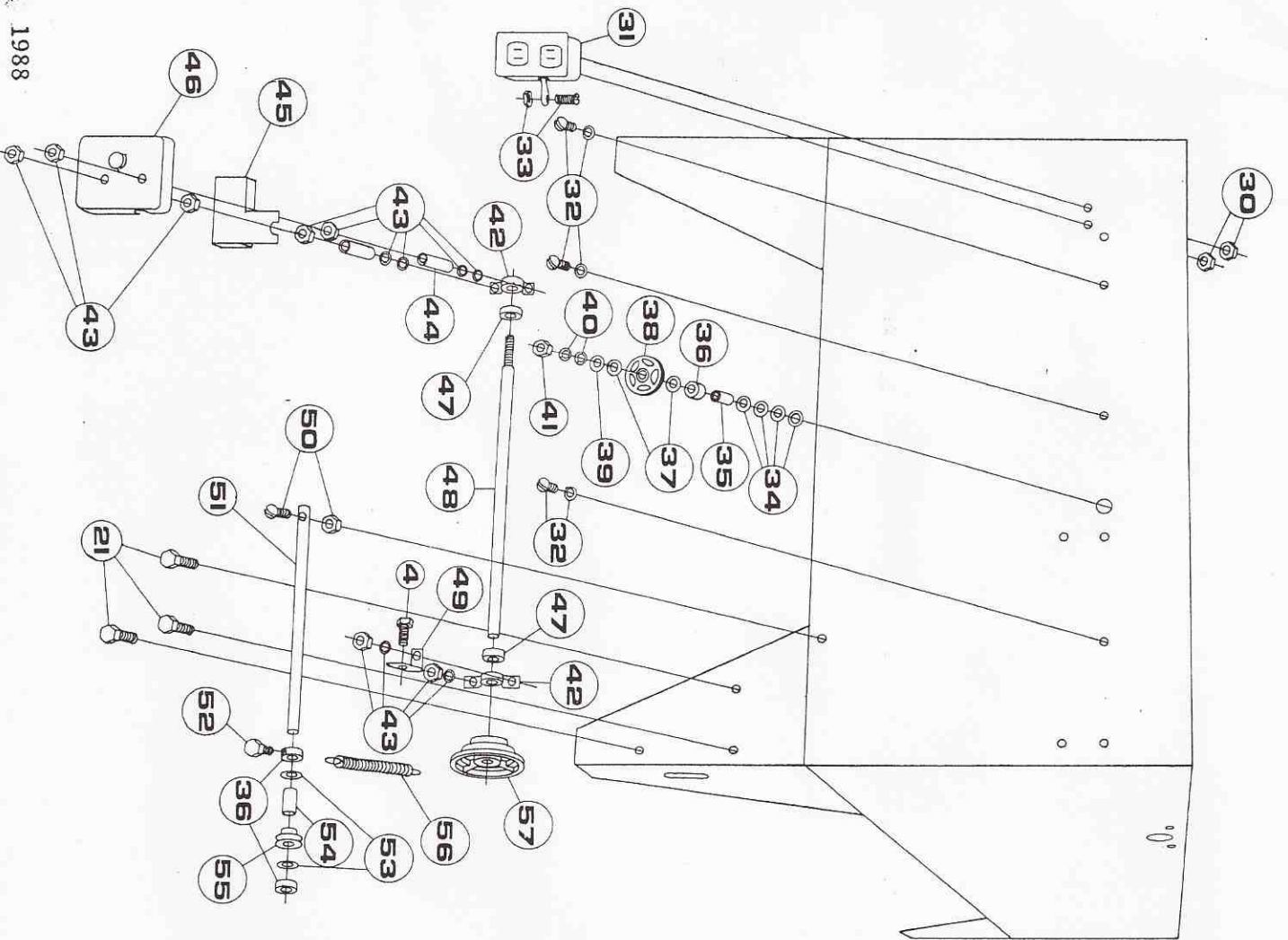

QTY	N/P	Description
* 2	30	1/4"-20 nuts + 1/4"-20 X 1/2 truss hd MS
* 1	31	1 hp toggle sw, 8' cord sw w/30"
* 5	32	wire, elec. bx & cover
* 1	33	1/4"-20 X 1 THMS & fiber washer
* 3	34	#4-40 X 3/4 RIMS & plastic lock nut
* 1	35	1/2" fiber spacer washer
* 1	36	1/2 X 3/8 X 1 1/4 L bronze bushing (#13553)
* 2	37	1/2" steel collar
* 1	38	3/8 X 1 fiber washer
* 1	39	4 X 3/8 bronze gear (G-187 Boston)
* 1	40	3/8" std steel washer
* 2	41	3/8" lock washer
* 1	42	3/8"24 std & jam nuts
* 2	43	5/8" pillow block (2X529)
* 7	44	1/4"-20 nut & washer
* 4	45	3/8 X 1/4 X 1 1/4 L spacers (tubing)
* 1	46	oil pan (#125 casting)
* 1	47	gear cover (#143 casting)
* 2	48	5/8 collar steel
* 1	49	5/8 X 15-3/4 worm shaft
* 1	50	belt guard bracket
* 1	51	#10-24 X 1 1/4 RHMS & nut
* 1	52	1/2 dia X 1 1/2 L idler shaft
* 2	53	1/4"-28 X 3/4 HHMS
* 1	54	1/2" fiber washer
* 1	55	5/8 X 1/2 X 1-1/8 L bronze bushing (1X868)
* 1	56	2A X 5/8 pulley
* 1	57	idler spring (#82 lane)
* 1	57	SCZ-6 X 5/8 pulley

# Also part of #660, #661, or #662 Saw Kits  
 \* Also part of #664, #665, or #666 Power Feed Kits





model 700 series  
slab saw

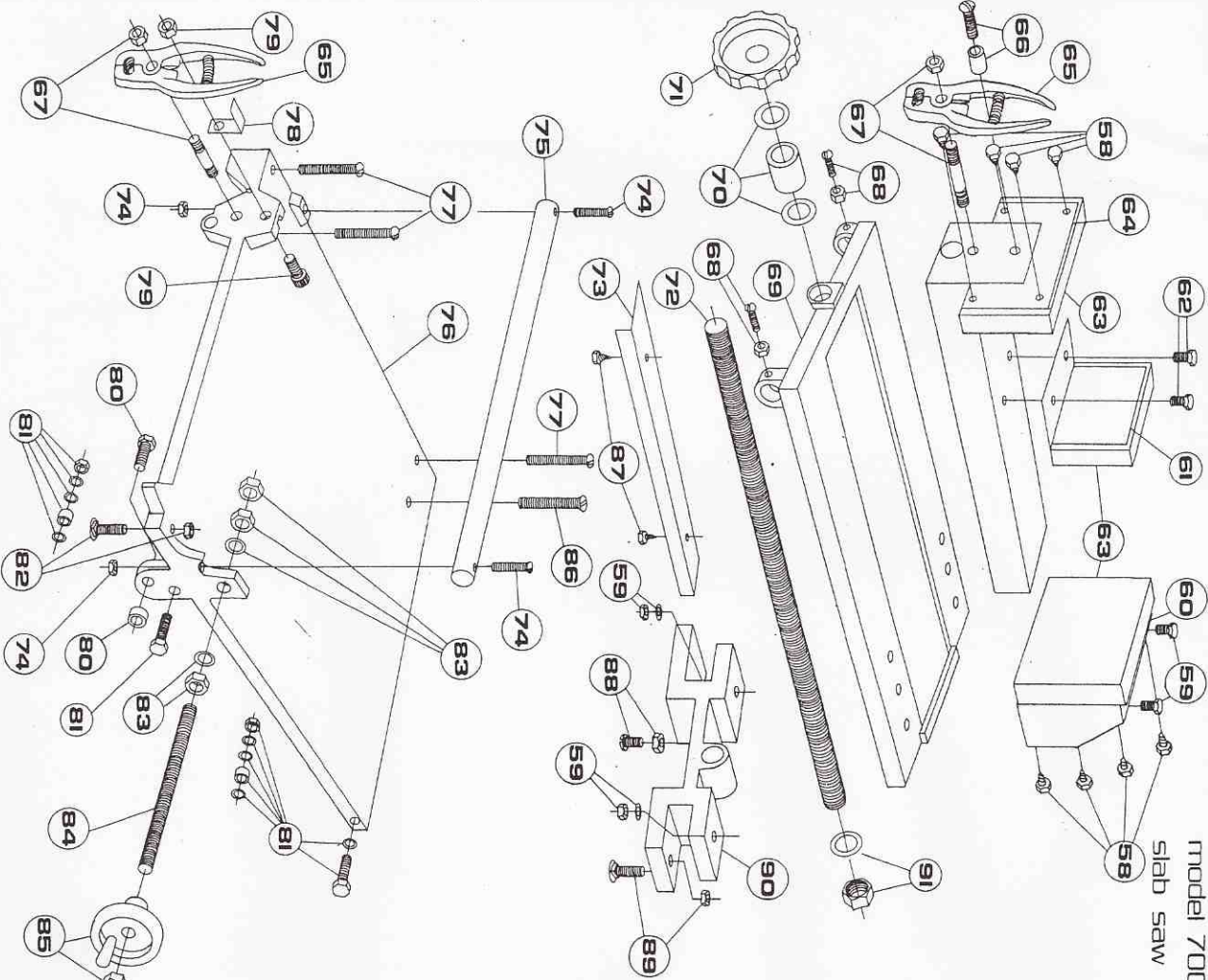

QTY	N/A	
# 8	58	#6 X 5/8 sheet metal screws
# 2	59	5/16"-18 X 2 HHMS, lock washer & nut
# 1	60	rear block (#87A casting)
# 1	61	middle block, 5 X 5 X 5/16 steel "L"
# 2	62	3/8"-16 X 3/4 HHMS
# 2	63	wooden block, 8 X 5 X 3/4
# 1	64	vise channel assy
# 1	65	pliers w/spring; #67 3/8"-16 stud & lock nut
* 1	66	(same as above)
# 1	65	plier lock (wing nut sleeve & 1/4"-20 X 2-1/8 RHMS)
# 2	68	Adj bolt (1/4"-20 X 3/4 RHMS) & nut
# 1	69	Vise frame (#86 casting, 18" Vise - #89)
# 1	70	1/2" sae washer, d.c. collar & nut
# 1	71	knob, 2 1/2 X 1/2 (NG 12)
# 1	72	vise screw rod (1/2"-13 thr)
# 1	73	vise shim
# 2	74	Vise cross shaft bolt (1/4"-20 X 2 1/4 RHMS) & nut
# 1	75	Vise cross shaft, 1/2" dia X 15 1/4
# 1	76	carriage (#85 casting)
# 3	77	1/4"-20 X 4 RHMS & nut
* 1	78	plier bracket
* 1	79	plier bracket bolt (#10-24 X 3/4 RHMS & nut
# 1	80	sw guide bolt (1/4"-28 X 3/4 & 1/4 X 3/4 X 1/4 thk washer)
# 1	81	Carriage ball bearing assy (1602-2RS, 1/4"-20 X 3/4 HHMS, 2-AN washer & lock nut
# 1	82	hold down bolt (elevator 1/4"-20 X 1 1/2) & nut
# 2	83	vise cross feed nuts (3/8"-16) & 1 - fibre washer
# 1	84	vise cross feed rod (3/8"-16 thr)
# 1	85	hand wheel (3" dia X 3/8 (19325) & nut
# 1	86	1/4"-20 X 4 FHMS & nut
# 2	87	#6-3/8 sheet metal screws
# 1	88	5/16"-18 X 2 1/2 THMS & jam nut
# 1	89	hold down bolt (elevator (1/4"-20 X 1) & nut
# 1	90	vise bridge (#87B casting)
# 1	91	vise washer & 1/2"-13 nut (welded)

# Also part of #660, #661, or #662 Saw Kits  
\* Also part of #664, #665, or #666 Power Feed Kits

model 700 series  
slab saw

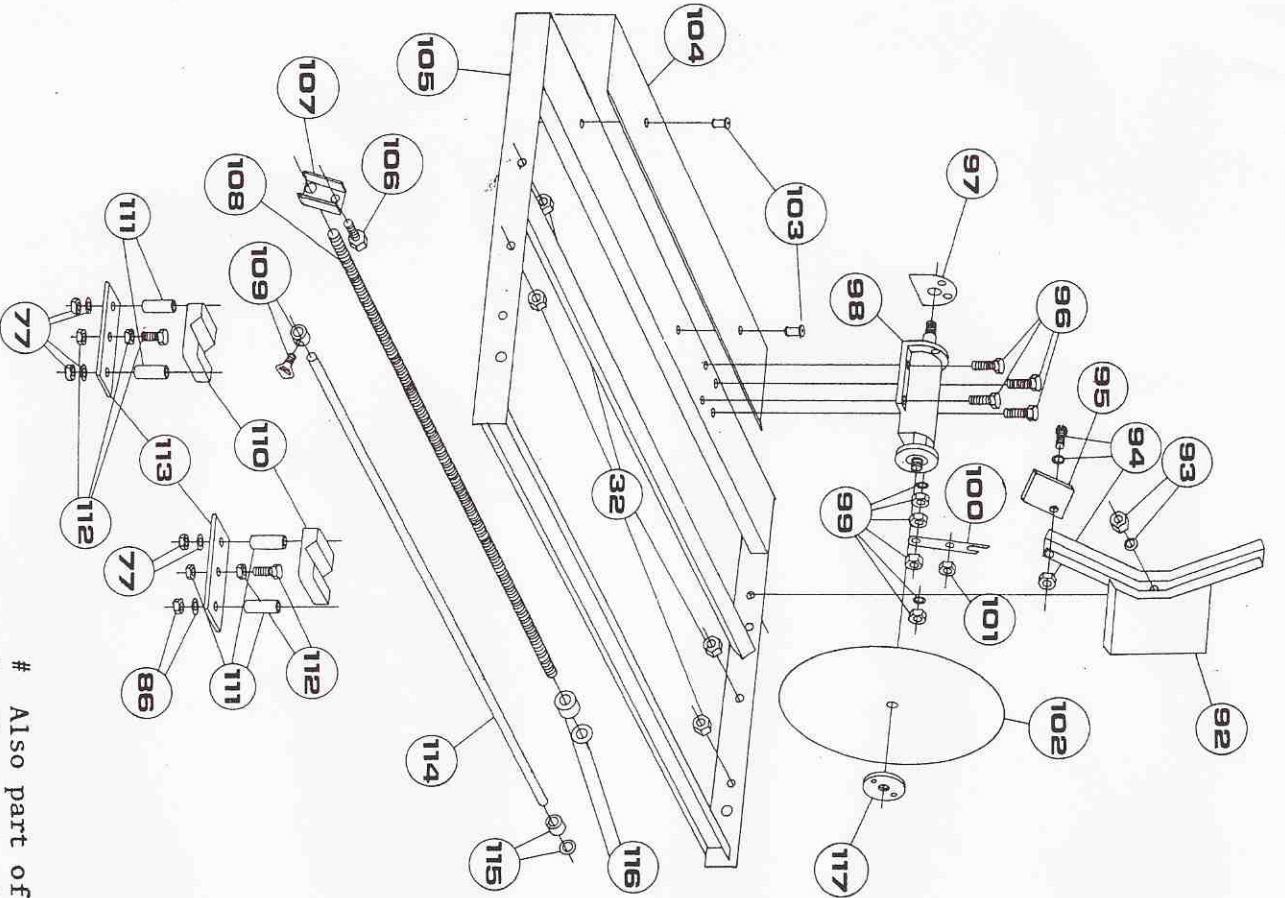

QTY	N/A	
1	92	blade guard
5	93	1/4"-20 X 3/4 RHMS, fiber washer & nut
1	94	#8-32 X 1/2 RHMS, fender washer & nut
1	95	splash pad (3" X 6" carpet)
4	96	5/16"-24 X 1 HHMS - high grade
2	97	arbor gasket, cork
1	98	#15 arbor assy
3	99	5/16"-18 std nut; 1 ea jam & locknut
1	100	lower prop arm
1	101	1/4"-20 X 1/2 RHMS & locknut
1	102	blade
1	103	1/4"-20 X 1/2 THMS, fiber washer
1	104	catch pan (18 ga, 8" X 21")
1	105	frame
1	106	lead scr guide (1/4"-20 X 3/4 HHMS)
1	107	lead scr guide bracket "u" channel (1/2" X 2") w/1/2" I.D. bronze bushing
1	108	lead screw (1/2"-13 X 36 1/2" L)
1	109	sw on/off collar (1/4" steel) and thumb screw (#10-32 X 1/2)
1	110	carriage "u" block, 1" X 2" X 2" milled (#163 casting)
4	111	carriage blk spacer (galv pipe, 1/8" X 5/8")
2	112	cap adj bolt (1/4"-20 X 1 1/4 & Sq Hd Nut
2	113	"u" block strap (1" X 3/4" X 3/16" thk)
1	114	switch rod (1/4" dia X 35 1/2" L)
2	115	1/4" seal bushing (SB-437-4) & 1/4" fiber washer
1	116	1/2" steel collar & fiber washer
1	117	arbor flange, 1"-14 R.H. thr

# Also part of #660, #661, or #662 Saw Kits  
\* Also part of #664, #665, or #666 Power Feed Kits

